

CONSTRUCTION

RESIN (ISOPHALIC POLYESTER) WITH FIBERGLASS REINFORCEMENT WITH A 16 TO 22 MILS THICK GELCOAT (U-V INHIBITED, NPG-ISO POLYESTER).

TOLERANCES

PART THICKNESS: +/- 1/16"
 GEL COAT THICKNESS: +/- 3 MILS
 LENGTH: +/- 1/16"
 HARDWARE LOCATION VARIATION: +/- 3/16"
 WEIGHT: +/- 8 OZ

FINISH

EXTERIOR: BLACK
 INTERIOR: UNFINISHED RESIN

WEIGHT (LBS.)	WIDTH	HEIGHT	DEPTH	PART NO.
15.00	56.50"	4.50"	16.00"	BT8D-DSP

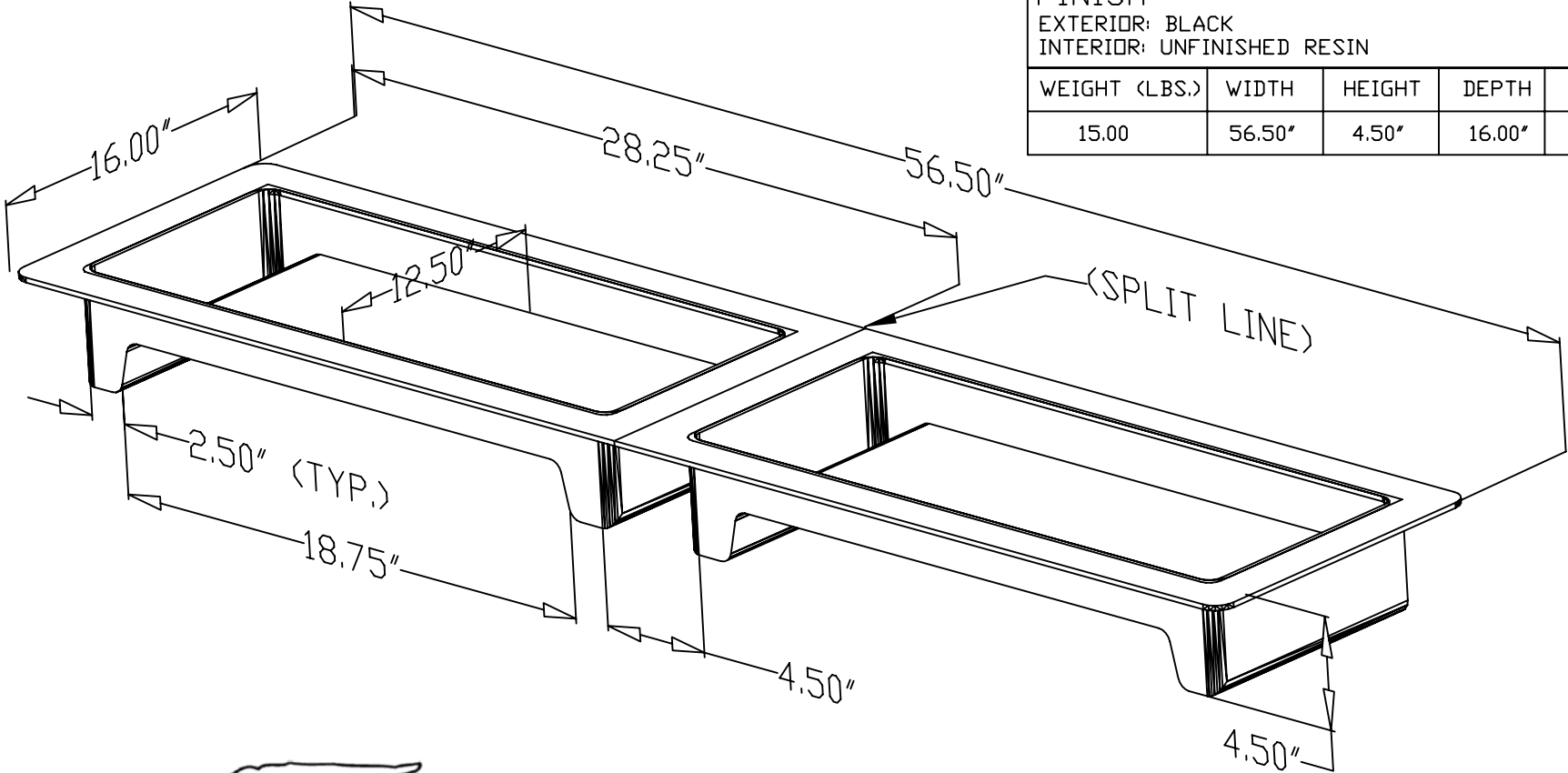

839 BILL FRANCE BLVD, DAYTONA BEACH, FL 32117
 PHONE (386) 274-2079 FAX (386) 274-2279
 WWW.DAVIDSONSALES.COM

TITLE: BT8D-DSP	DRAWN BY: JS	SCALE: NONE
	CHECKED:	DATE: 08/03/07
UNLESS OTHERWISE SPECIFIED: ALL DIMENSIONS ARE IN INCHES NOT TO SCALE		PART NUMBER: BT8D-DSP
SHEET 1 OF 1		